



2025 PRIMARY 4 END-OF-YEAR EXAMINATION

Name : _____ ()

Date: 30 October 2025

Class : Primary 4 ()

Time: 8.00 a.m. - 9.30 a.m.

Duration: 1 hour 30 minutes

SCIENCE

BOOKLET A

INSTRUCTIONS TO CANDIDATES

1. Write your name, class and register number.
2. Do not turn over this page until you are told to do so.
3. Follow all instructions carefully.
4. Answer all questions.
5. Shade your answers on the Optical Answer Sheet (OAS) provided.

Booklet A (26 x 2 marks)

For each question from 1 to 26, four options are given. One of them is the correct answer. Make your choice (1, 2, 3 or 4) and shade your answer on the Optical Answer Sheet.

(52 marks)

1. A hen lays eggs as shown in the picture below.

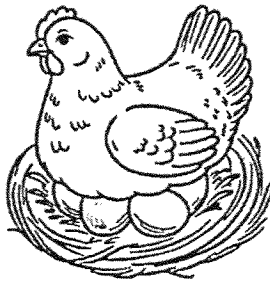

This shows that the hen is a living thing because it can _____.

- (1) grow
(2) breathe
(3) respond
(4) reproduce
2. Which one of the animals shown below is **not** an insect?

(1)

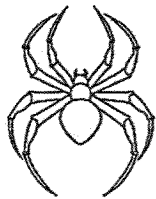

(2)

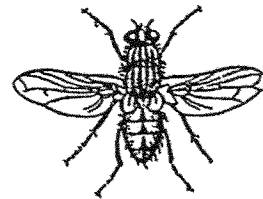

(3)

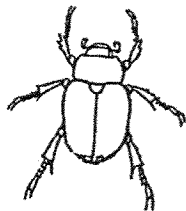

(4)



3. Which one of the following shows the correct order when food moves through some parts of the digestive system?

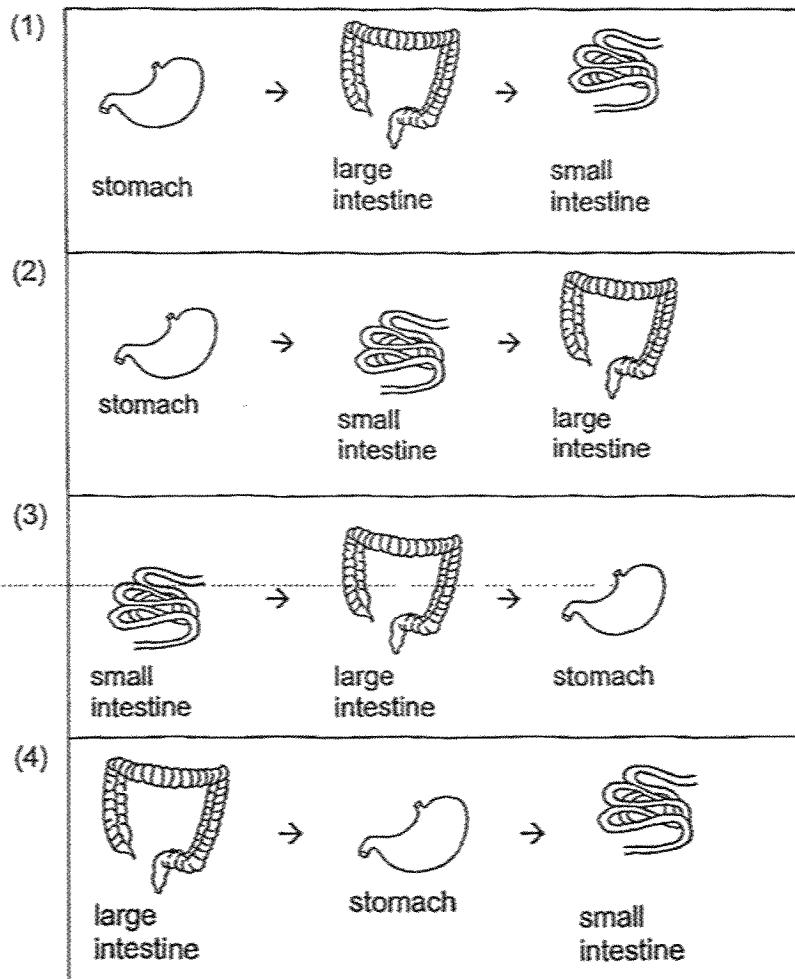

4. Amin made the following observations on the life cycle of an animal.

- There are three stages in the life cycle.
- The young looks like the adult.

Which animal was Amin observing?

- (1) frog
(2) beetle
(3) mosquito
(4) grasshopper

5. Object A was attracted to a magnet, as shown in the figure below.

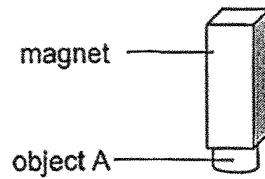

Object A is made of _____.

- (1) wood
 - (2) steel
 - (3) glass
 - (4) plastic
6. Which one of the following properties is true for both air and a ruler?

- (1) They can be seen.
- (2) They take up space.
- (3) They have fixed shapes.
- (4) They have fixed volumes.

7. Which of the following is a source of light?

(1)



the moon

(2)



a leaf

(3)



a campfire

(4)

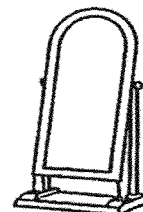

a mirror

8. Warm water at 70°C is mixed with cold water at 10°C.

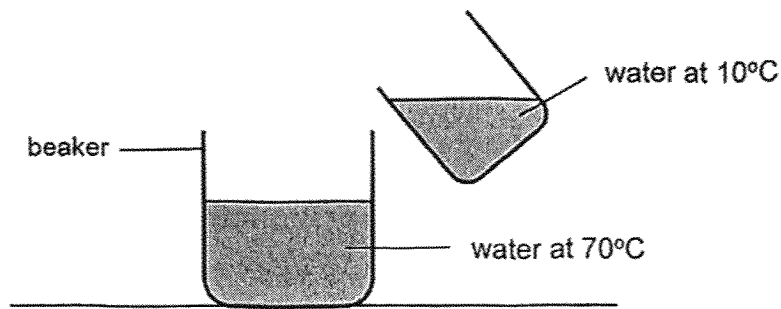

What is the possible final temperature of the water in the beaker?

- (1) 75°C
 - (2) 70°C
 - (3) 50°C
 - (4) 10°C
-
9. Sam observed the life cycle of an insect and recorded the duration of growth in each stage.

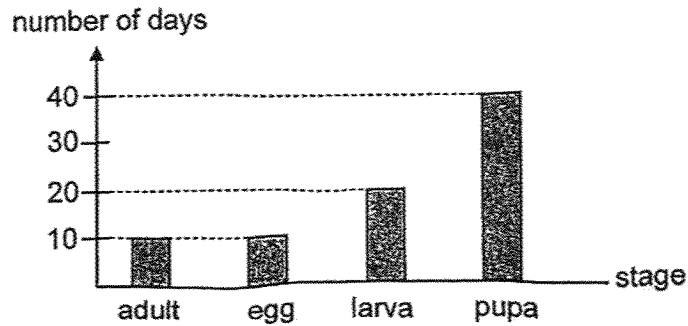

Based on the graph above, which statement is true?

- (1) The insect gives birth to its young.
- (2) The insect remains as a larva for 30 days.
- (3) The insect spends most of its life cycle as a pupa.
- (4) The insect has the same number of stages as a cockroach.

10. Study the flowchart.

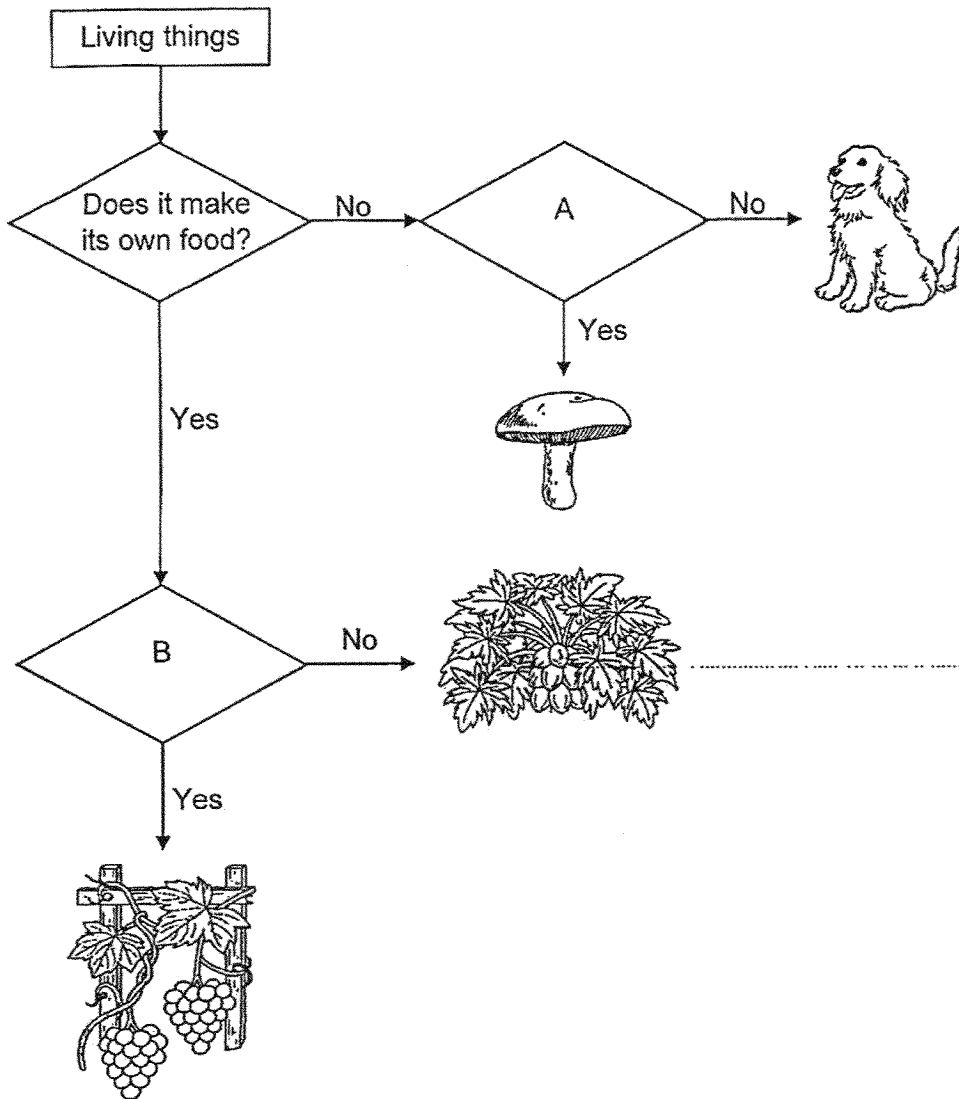

Based on the flowchart above, which of the following is represented by the questions, A and B?

	A	B
(1)	Does it reproduce by seeds?	Does it have weak stem?
(2)	Does it reproduce by spores?	Does it have weak stem?
(3)	Does it reproduce by seeds?	Does it have strong stem?
(4)	Does it reproduce by spores?	Does it have strong stem?

11. The diagram shows a water plant in a pond.

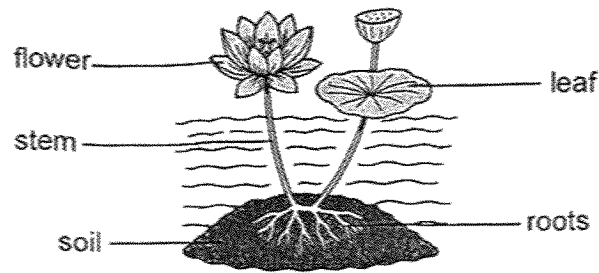

Based on the water plant above, which plant part and its function is **not correct**?

	Plant part	Function
(1)	stem	absorb water and mineral salts
(2)	roots	hold the plant firmly to the ground
(3)	leaf	take in and give out gases
(4)	flower	develop into a fruit

12. The diagram shows part of the large intestine in the human digestive system.

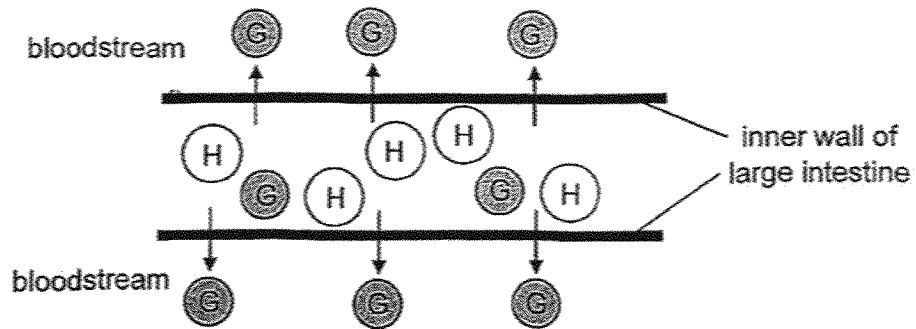

Which of the following represents substances G and H correctly?

	G	H
(1)	digested food	water
(2)	water	digested food
(3)	water	undigested food
(4)	digested food	undigested food

13. The diagram below shows a human digestive system with parts P, Q, R and S.

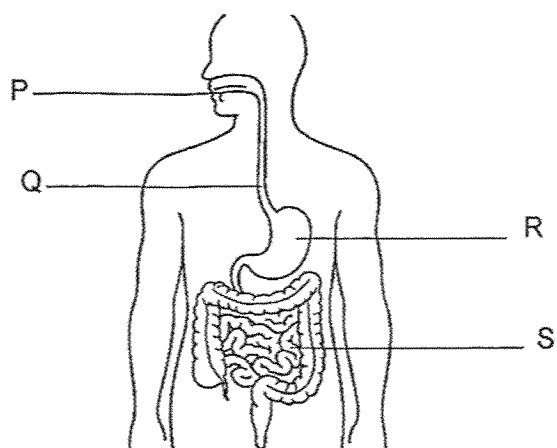

Which of the following shows the changes in the amount of digested food from the time it enters until it leaves each of the parts P, Q, R and S?

	P	Q	R	S
(1)	increase	no change	increase	increase
(2)	increase	no change	increase	no change
(3)	increase	increase	no change	increase
(4)	no change	increase	increase	increase

14. The properties of materials K, L, M and N are shown in the table.

A tick (✓) represents that the material has the property.

Properties	K	L	M	N
strength	✓	✓		✓
flexible	✓		✓	✓
waterproof	✓	✓	✓	

The diagram below shows a slide.

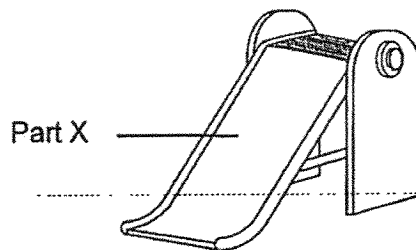

Which material is the most suitable for making part X of the slide?

- (1) K
- (2) L
- (3) M
- (4) N

15. David placed a bar magnet above a box of iron filings that had been evenly spread as shown in the diagram.

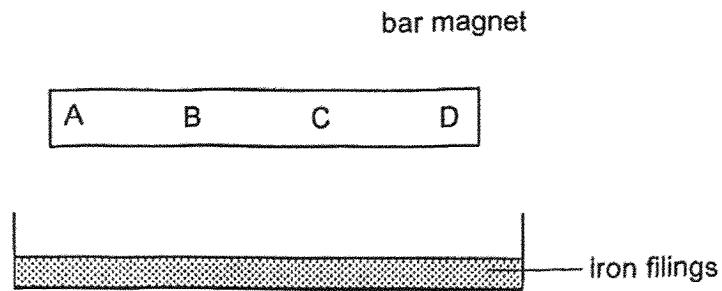

At which parts of the bar magnet, A, B, C or D, would David find the greatest amount of iron filings attracted to them?

- (1) A and B
(2) A and D
(3) B and C
(4) C and D
16. Four rings, S, T, U and V, are slotted into the plastic rod one at a time in the set-up below. Among the four rings, two are ring magnets and two are iron rings.

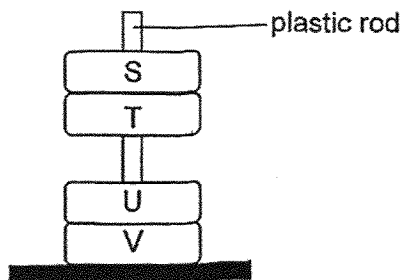

Which two are the iron rings?

- (1) S and T
(2) T and U
(3) U and V
(4) V and S

17. The diagram shows a container containing some water.

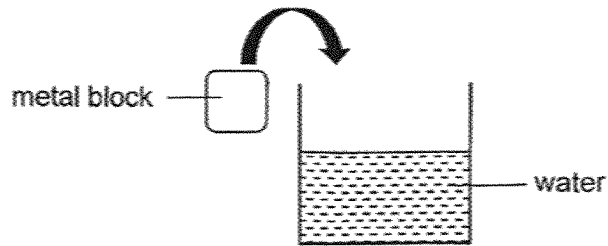

What will happen to the water level and the volume of water in the container after a block is placed into it?

	water level	volume of water
(1)	increases	increases
(2)	increases	remains the same
(3)	decreases	increases
(4)	decreases	remains the same

18. A 1000 cm^3 container was filled with 400 cm^3 of oil. The container was sealed with a cover and a plunger was attached to it as shown in the diagram.

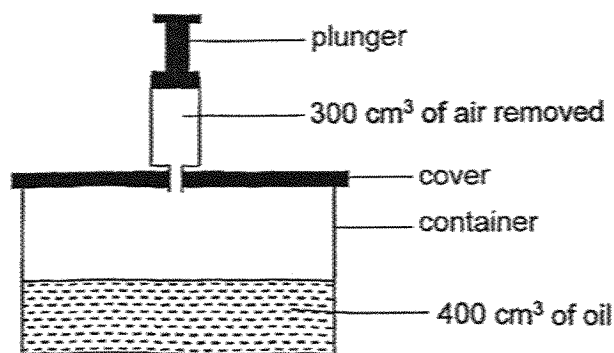

Ken removed 300 cm^3 of air from the container. Which statement is correct?

- (1) The mass of the air in the container increased.
- (2) The volume of the air in the container decreased.
- (3) The mass of the air in the container remained the same.
- (4) The volume of the air in the container remained the same.

19. Anne placed object X in front of a torch to cast a shadow on the screen as shown in the diagram. When the object is at E, the size of the shadow formed is 10 cm.

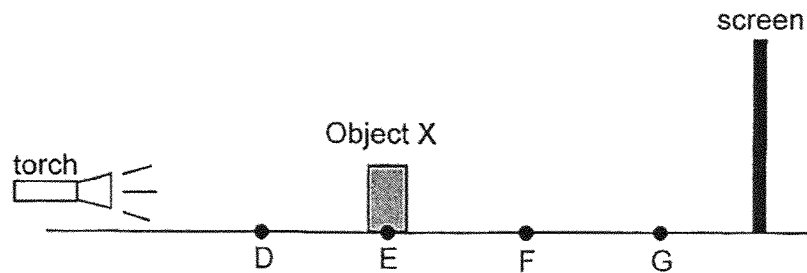

Which of the following correctly shows the size of the shadow cast on the screen when object X is placed at D, F and G?

	size of shadow [cm]		
	D	F	G
(1)	12	14	16
(2)	8	6	4
(3)	12	8	6
(4)	8	12	14

20. Jonas looks into a cake display counter as shown below.

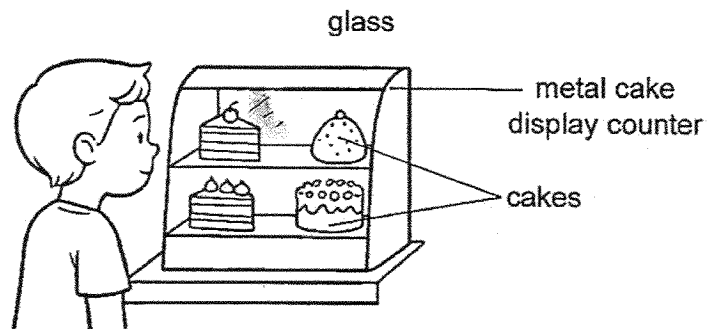

Which statement explains why he can see the glass?

- (1) Light is reflected from the cakes.
- (2) No light passes through the metal.
- (3) Light passes through the glass easily.
- (4) Some light is reflected from the glass.

21. In a dark room, light was shone at an opaque object from direction Y and Z at different timings as shown below.

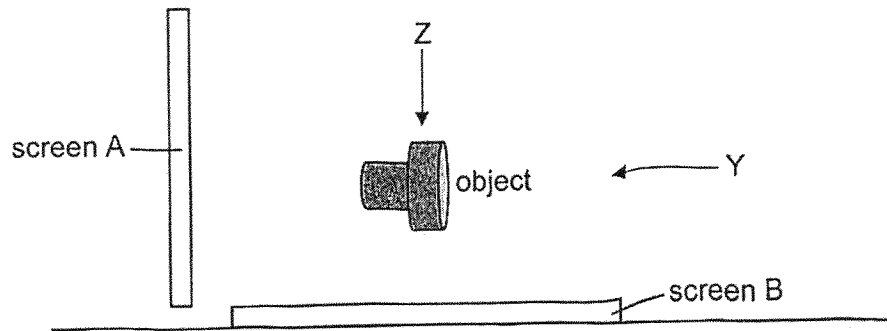

Which of the following shows the correct shadow cast on screen A and B?

	shadow on screen A	shadow on screen B
(1)		
(2)		
(3)		
(4)		

22. Bala placed an object between the torch and the screen as shown in the diagram.

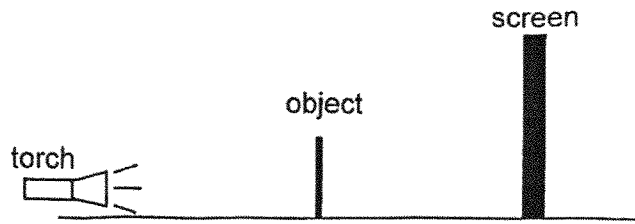

The object is made up of different materials as shown below.

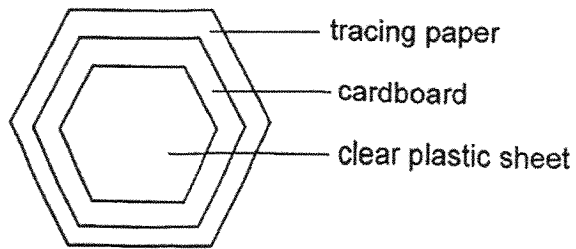

Which shadow will Bala likely see on the screen?

(1)

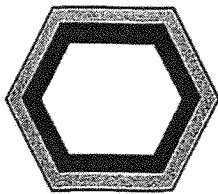

(2)

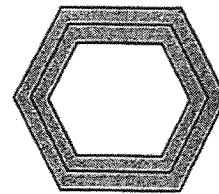

(3)

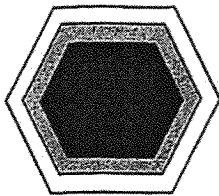

(4)

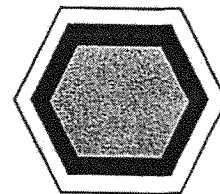

23. Liquid W is left to cool down on a table in the classroom. The graph below shows the temperature of liquid W over a duration of 15 minutes.

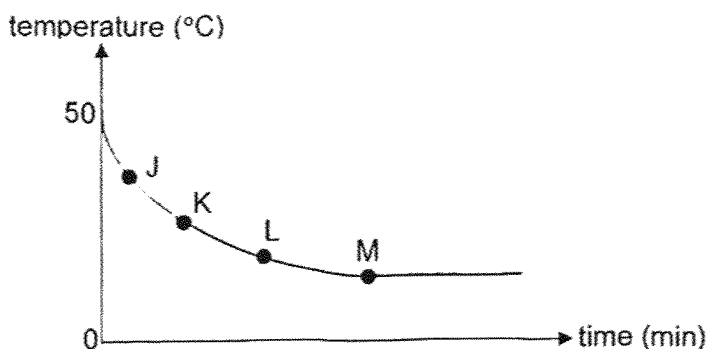

At which point, J, K, L or M, has liquid W reached room temperature?

- (1) J
- (2) K
- (3) L
- (4) M
-
24. Ben placed two tiles, Q and R, on the floor in an air-conditioned room which was at a temperature of 22°C overnight. Both tiles were of similar size but made of different materials.

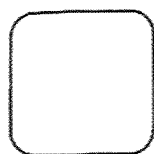

tile Q

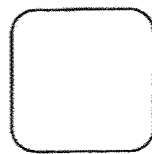

tile R

Why did Ben's foot feel colder when he stepped on tile R?

- (1) Tile R lost more heat to Ben's foot than tile Q
- (2) Tile R is a ~~better~~ conductor of heat than tile Q.
- (3) Tile R is a poorer conductor of heat than tile Q.
- (4) Tile R lost more heat to the surroundings than tile Q.

25. Kai Ling heated three identical metal cubes, P, Q and R, to different temperatures. He put the metal cubes into three beakers each containing the same amount of cold water at 20°C as shown in the diagram.

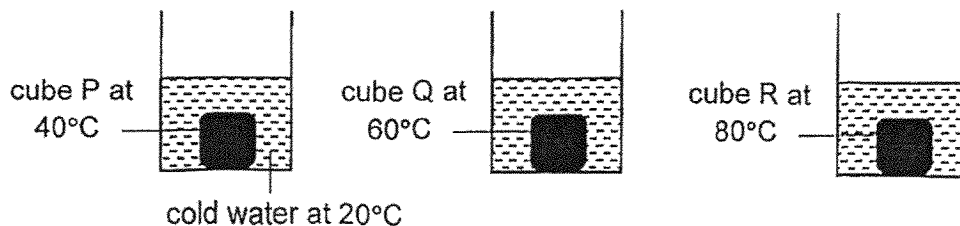

He recorded the temperature of the water after 5 minutes in the table shown.

metal cube	P	Q	R
temperature of water in the beaker after 5 minutes (°C)	34	44	50

What was the aim of Kai Ling's experiment?

- (1) To find out if the metal cube is a better conductor of heat than water.
- (2) To find out if heat can be transferred from the metal cubes to the water in the beaker.
- (3) To find out if the temperature of the water in the beaker affects the amount of time for the metal cube to lose heat.
- (4) To find out if the start temperature of the metal cube affects the final temperature of the water in the beaker.

26. Mira placed three beakers, C, D and E, with different amounts of water at 30°C on the electric plate. The beakers were heated till the water reached 70°C.

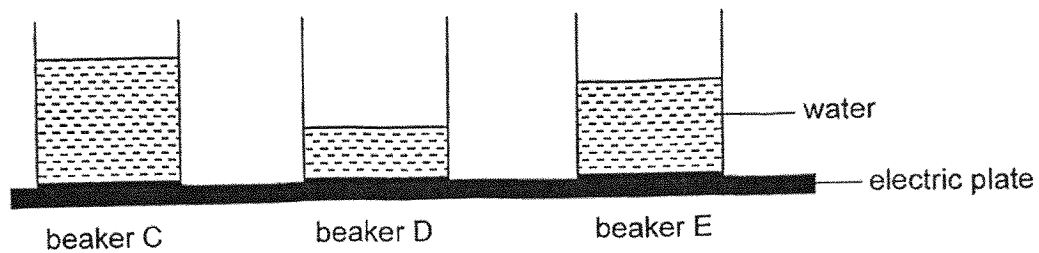

Based on the setup above, arrange beakers, C, D and E, beginning with the beaker of water that took the shortest time to reach 70°C to the beaker that took the longest time.

Which of the following is the correct arrangement?

	shortest time → longest time
(1)	C → D → E
(2)	D → E → C
(3)	C → E → D
(4)	E → D → C

End of Booklet A



2025 PRIMARY 4 END-OF-YEAR EXAMINATION

Name : _____ ()

Date: 30 October 2025

Class : Primary 4 ()

Time: 8.00 a.m. – 9.30 a.m.

Parent's Signature : _____

Duration: 1 hour 30 minutes

SCIENCE

BOOKLET B

INSTRUCTIONS TO CANDIDATES

1. Write your name, class and register number.
2. Do not turn over this page until you are told to do so.
3. Follow all instructions carefully.
4. Answer all questions.
5. Write your answers in the booklet.

Booklet A	52
Booklet B	28
Total	80

Booklet B (28 marks)

For questions 27 to 36, write your answers clearly in this booklet.

The number of marks available is shown in brackets [] at the end of each question or part question.

(28 marks)

27. James observed and grouped some things as shown in the table below.

S	T
chair	cat
pencil	tree
bicycle	butterfly

What are the suitable headings for S and T?

[2]

Group S: _____

Group T: _____

28. Tick (✓) the box if each of the following has a definite shape and/or a definite volume. [2]

		Has definite shape	Has definite volume
(a)	tea		
(b)	glass pot		

29. The diagram below shows two plants.

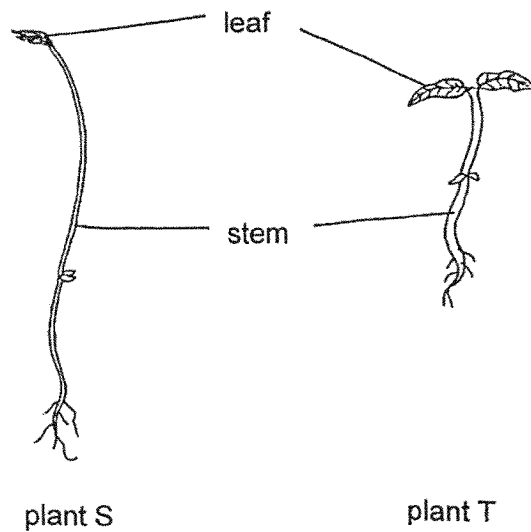

(a) State one difference between the stem of plant S and the stem of plant T?

The stem of plant S is _____ than the stem of plant T. [1]

(b) The leaves help both plants make _____ in the light. [1]

30. The diagram below shows a pot.

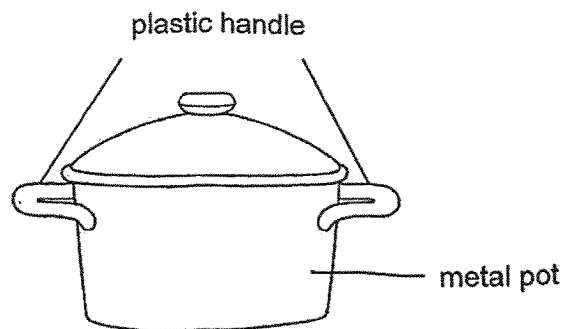

(a) The handle is made of plastic because it is a _____ conductor of heat. [1]

(b) The pot is made of metal because it is a _____ conductor of heat. [1]

Score	4
-------	---

31. The diagrams below show the life cycle of 2 insects, X and Y.

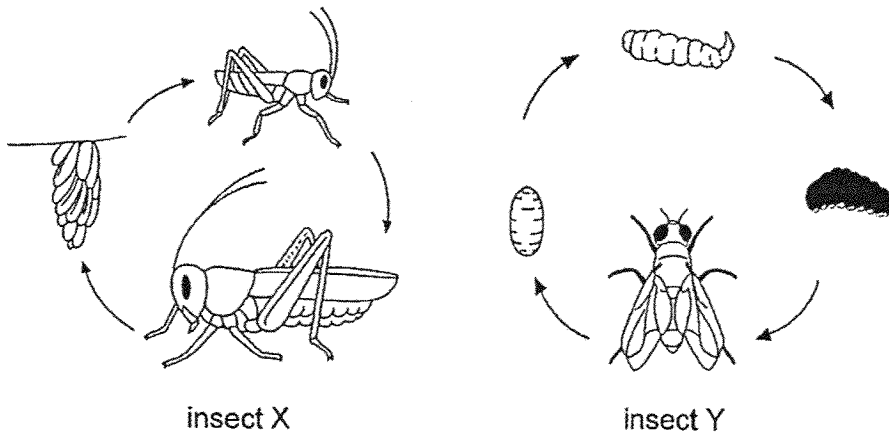

(a) Based on the diagrams above, state one difference between the life cycle of insects X and Y. [1]

(b) What is the advantage of insect X laying many eggs at one time? [1]

	2
Score	2

32. Afifah placed 150 cm^3 of cooked potatoes in containers A, B and C as shown below. She filled each container with 800 cm^3 of digestive juice and cut the potatoes into different number of pieces in containers B and C.

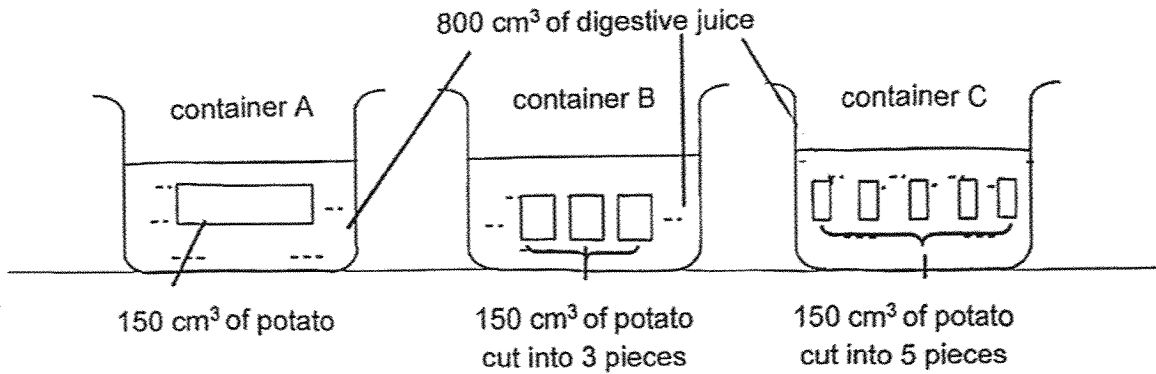

(a) What is digestion? [1]

(b) In which container will the potato take the longest time to completely digest? Explain why. [2]

Afifah uses 500 cm^3 of digestive juice in container B in another experiment.

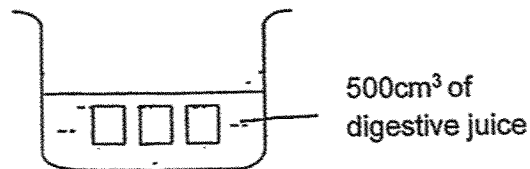

(c) He observed that the time taken for digestion to take place remains the same. Explain why. [1]

Score	4
-------	---

33. Mohan conducted an experiment using two objects, E and F, which are identical in size and shape. In set-up 1, he compared the mass of the two objects.

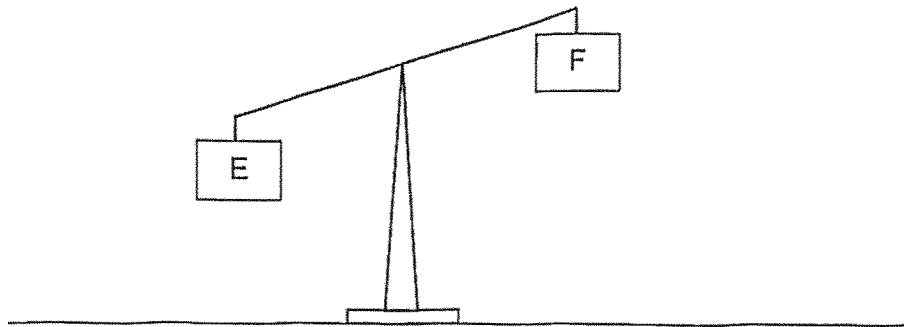

Set-up 1

He then compared the volume of objects E and F by lowering each object into the water of the same volume as shown below in set-up 2.

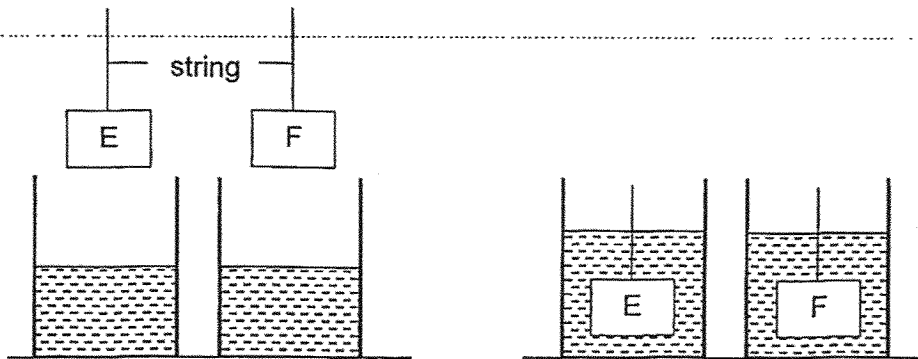

Before

After

Set-up 2

(a) Based on the results of his experiment, what could Mohan conclude about the mass and volume of objects E and F? [2]

Score	2
-------	---

(b) Mohan conducted another experiment where he added some water in a measuring cylinder before he placed object Z in it. The diagram below shows his observations.

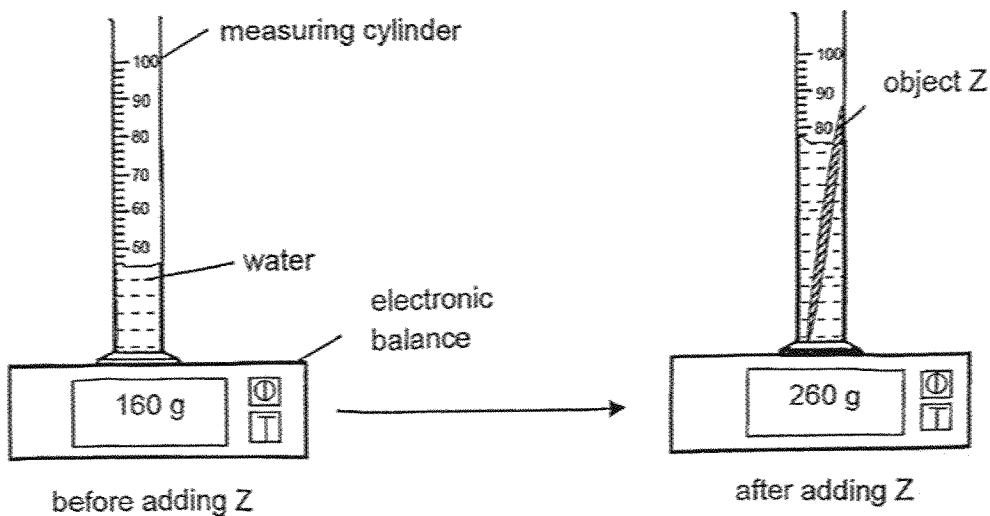

(i) Based on Mohan's observations, what is the mass of object Z? [1]
Place a tick (✓) in the correct box below.

Mass of object Z	(✓)
Less than 100 g	
Exactly 100 g	
More than 100 g	
Not possible to tell	

(ii) Based on the experimental set-up, explain why Mohan was unable to measure object Z's volume accurately? [1]

Score	2
-------	---

34. Augustine set up an experiment in a dark room as shown below.

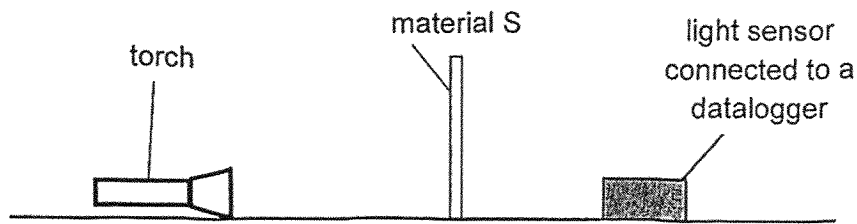

He recorded the amount of light detected by the light sensor and repeated the experiment using materials T and U.

When no material was placed between the torch and the light sensor, the amount of light detected was 1450 units.

The results of his experiment are shown in the table below.

Material	Amount of light (unit)
S	0
T	1388
U	110

(a) Based on the results above, arrange the three materials, S, T and U in decreasing order of the amount of light passing through the materials. [1]

Greatest amount of light passing through \longrightarrow Least amount of light passing through

Score	1
-------	---

(b) The diagram below shows the positions of a light source, puppet, screen and audience.

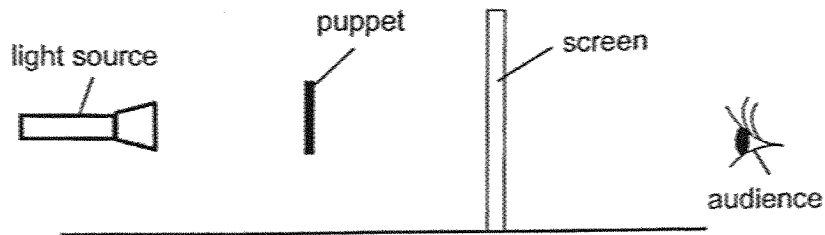

The audience will be able to view the shadow puppetry on the screen as shown below.

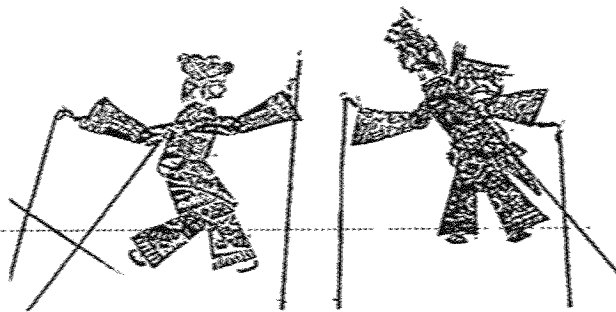

(i) Explain how the shadow of the puppet is formed on the screen. [1]

(ii) Based on the results of Augustine's experiment, which material, S, T or U, will he choose to make the screen for the shadow puppetry? Explain why. [2]

Score	3
-------	---

35. Adrianna wanted to find out how a drop of coloured dye in a glass tube moves when the test tube is placed in water at different temperatures.

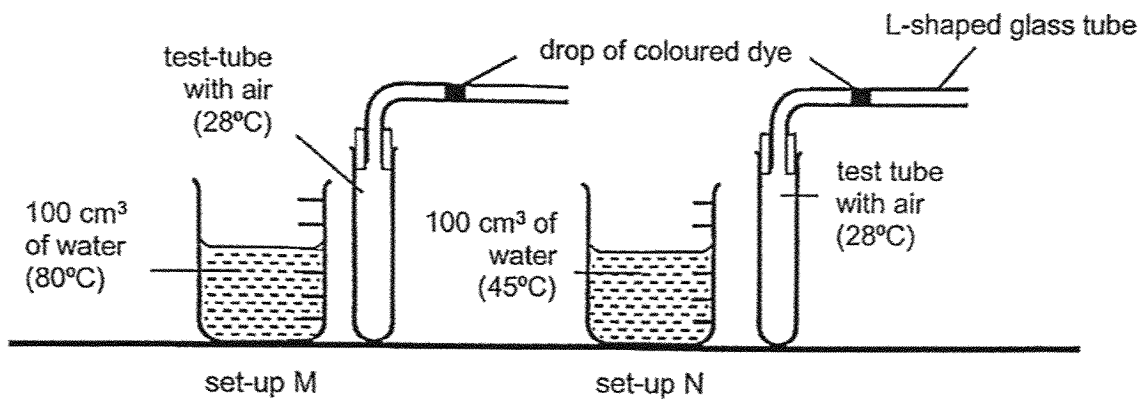

Diagram 1: Before test tubes are placed inside the beakers

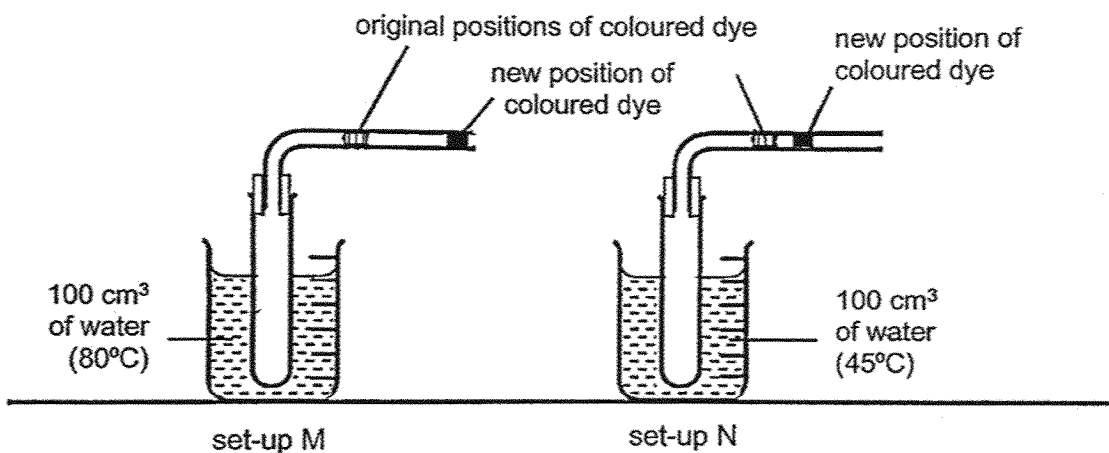
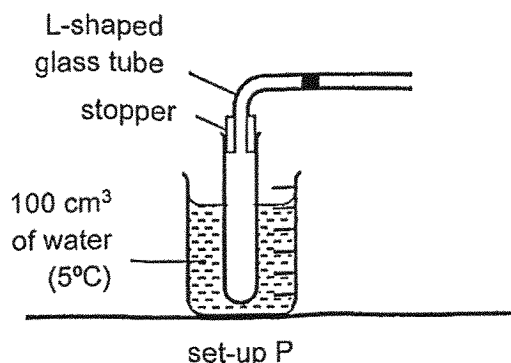

Diagram 2: After test tubes are placed inside the beakers

(a) Explain why the drop of coloured dye in set-up M moved a greater distance to the right than that in set-up N. [2]

Score	2
-------	---

- (b) Adrianna repeated the experiment with the same volume of air, at 28°C in the test tube, but with the beaker containing 100 cm³ of water at 5°C.



- (i) Place a tick (✓) in the table to indicate the new position which the drop of coloured dye will move to in set-up P. [1]

<p>Move to the left (towards the bend of the glass tube)</p>		
<p>Remains at the same position</p>		
<p>Move to the right (away from the bend of the glass tube)</p>		

- (ii) Based on the concepts of heat transfer, explain your answer in (b)(i). [1]

36. Indranee set up three wooden boards with holes in the middle and a candle flame as shown below.

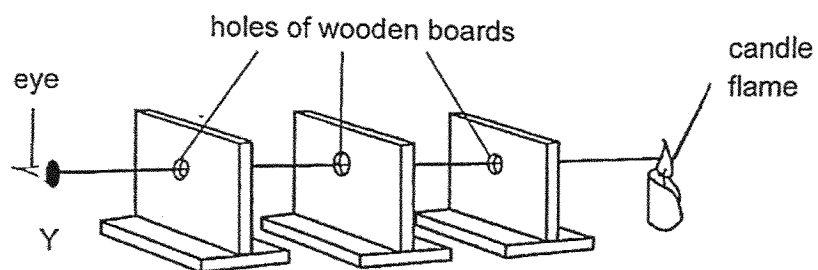

Using one property of light, explain why Indranee could see the candle at Y. [2]

End of Paper

Score	2
-------	---

SCHOOL : TAO NAN PRIMARY SCHOOL
LEVEL : PRIMARY 4
SUBJECT : SCIENCE
TERM : 2025 END OF YEAR EXAMINATION

Q1	Q2	Q3	Q4	Q5	Q6	Q7	Q8	Q9	Q10
4	1	2	4	2	2	3	3	3	2
Q11	Q12	Q13	Q14	Q15	Q16	Q17	Q18	Q19	Q20
1	3	1	2	2	4	2	4	3	4
Q21	Q22	Q23	Q24	Q25	Q26				
3	1	4	2	4	2				

27	Group S: Non-living (things) Group T: Living (things)
28	a) has definite volume b) has definite shape
29	a) thinner / longer / taller b) food
30	a) poor b) good
31a	Insect X has a 3-stage life cycle while insect Y has a 4-stage life cycle. OR Insect Y has a larva / pupal / pupa stage while insect X does not (have a larva / pupal / pupa stage) OR Young of X resembles the adult but young of Y does not.
31b	To increase the chances of eggs hatching and develop into young / adults.
32a	Digestion is the process where food is broken down into simple / simpler substances.
32b	Container A. The potato has the smallest (exposed) surface area in contact with the digestive juice.
32c	The amount of size of potato's surface area (in contact with the digestive juice) remains the same.
33a	E has a greater mass than F. The volume of E and F are the same.
33b	(i) Exactly 100g (ii) Z is not fully submerged (in the water).
34a	T, U, S

34bi	Puppet is opaque/ does not allow light to pass through it/ light is blocked by the puppet,
34bii	C: U E: translucent/ allows some light to pass through R: Audience will still be able to see the shadow (on the screen)
35a	Water in M is at a higher temperature than that in N. Air in the test-tube in M gains more heat/ heat faster from the water. Hence, the air expands more.
35bi	Move to the left (✓)
35bii	Air in the test tube loses heat to the water and contracts.
36	Light could travel in a straight line. Hence the light from the candle flame could pass through the holes and enter the eye.